

MATLAB EXPO

基于Simulink环境的永磁同步电机控制仿真系统的介绍
孙翔，上海西门子电动汽车有限公司R&D 软件部门



我们是一家跨国企业，在德国、法国和中国均有研发与工厂

VSeA 研发与工厂



VSeA全球拥有2000名研发工程师，致力于汽车高压动力系统

客户应用车型每年都有增加

launch of
90 vehicles
up to **2022**



Volvo V60



BMW i3



Renault



Volvo



Chevrolet Malibu



Renault Kangoo



BMW 730e



Smart



Smart



Renault Master



BMW F10



GAC Trumpchi GE3



BAIC



Cadillac XT5



GMC Sierra
Chevrolet Silverado



Great Wall P8



eGO Life



Volvo XC60



Volvo S90



Volvo V90



DS7 Crossback e-tense



Peugeot



Opel GrandLand



BAIC



Tata



Renault



Land Rover Discovery



Renault



Renault



Volvo Polstar



BJEV Arcfox



VW ID3



And 60 more to come

2012

2013

2014

2015

2016

2017

2018

2019

2020 ...

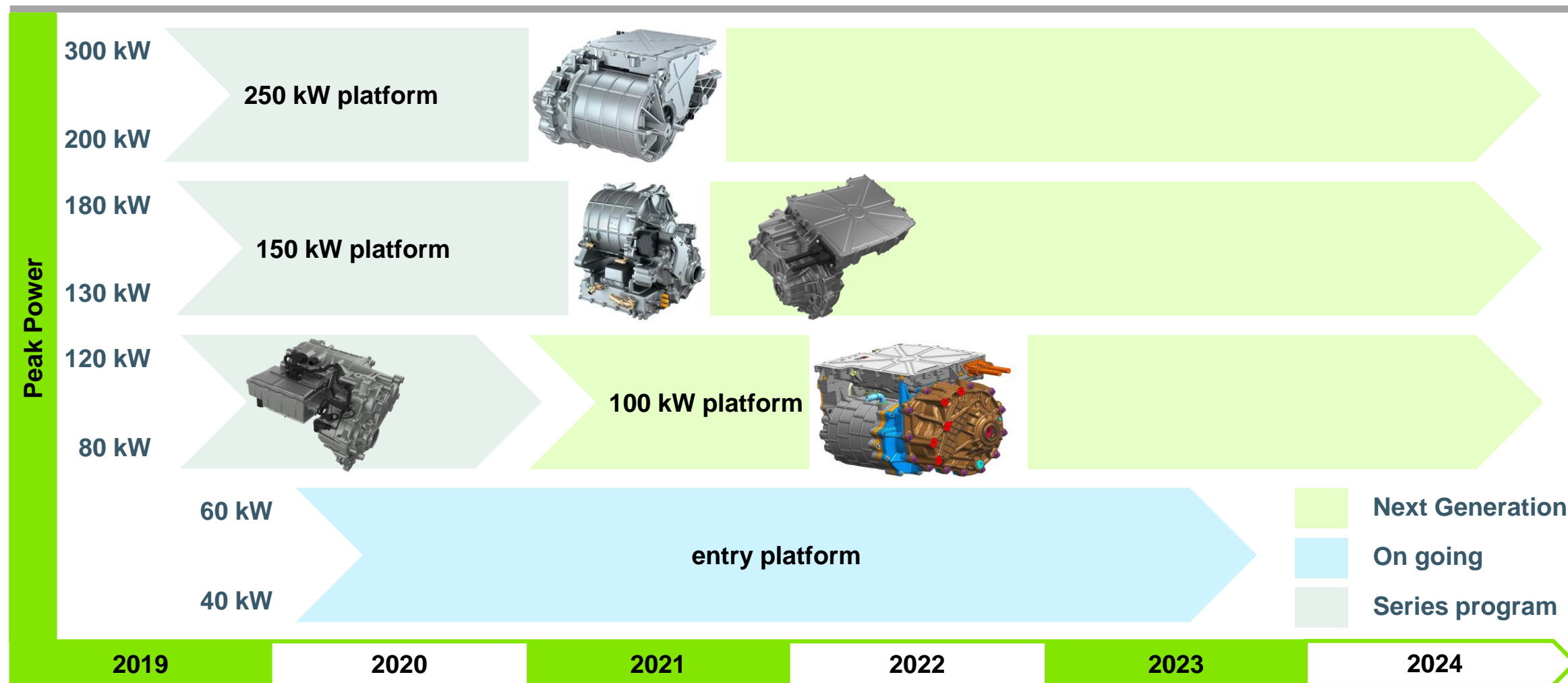

VSeA achievements : VW MEB / Volvo Polstar / PSA PHEV / Great Wall P7&P8 / JLR / Renault Zoe

eAxle 产品线概览

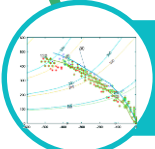
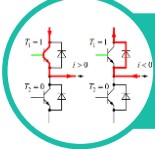

Full eAxle portfolio for BEV and PHEV existing

目录

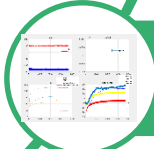
-  PMSM-Inverter 闭环控制系统介绍
-  结合实验数据的永磁同步电机模型
-  采用数学模型对Inverter进行精准建模
-  软件策略的早期验证
-  利用MATLAB 处理实验与仿真数据

车用永磁同步电机控制系统介绍

- 动力控制系统是一个复杂的多产品组合

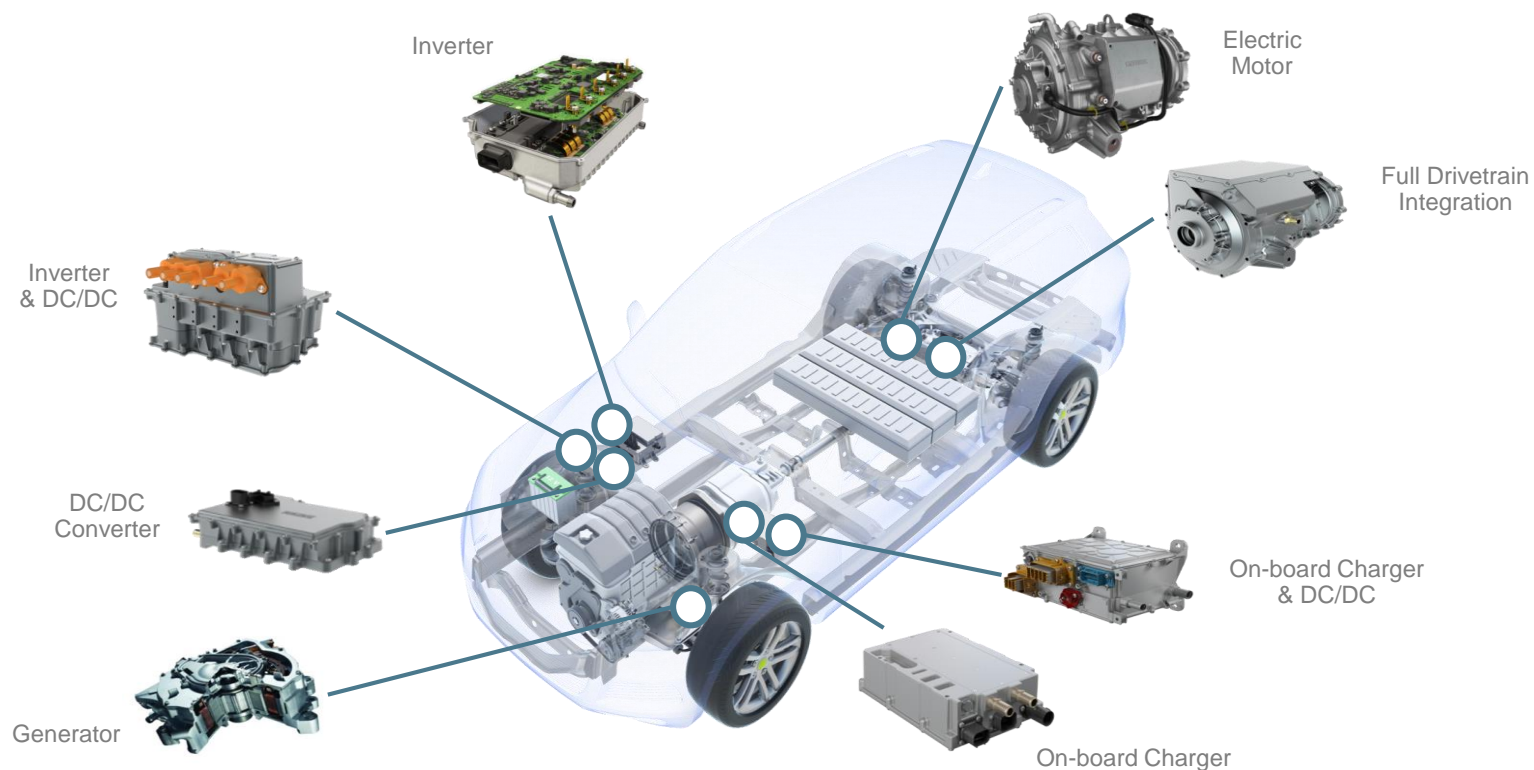

车用永磁同步电机控制系统介绍

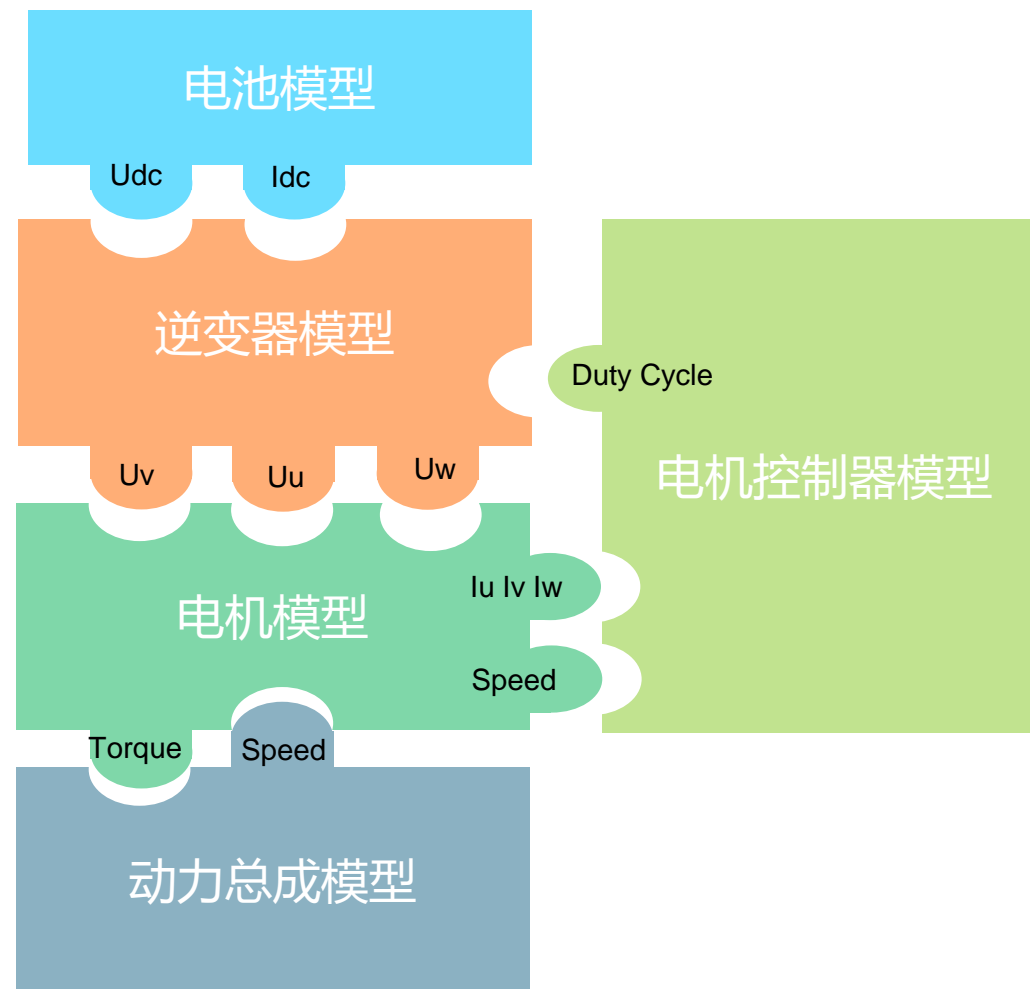
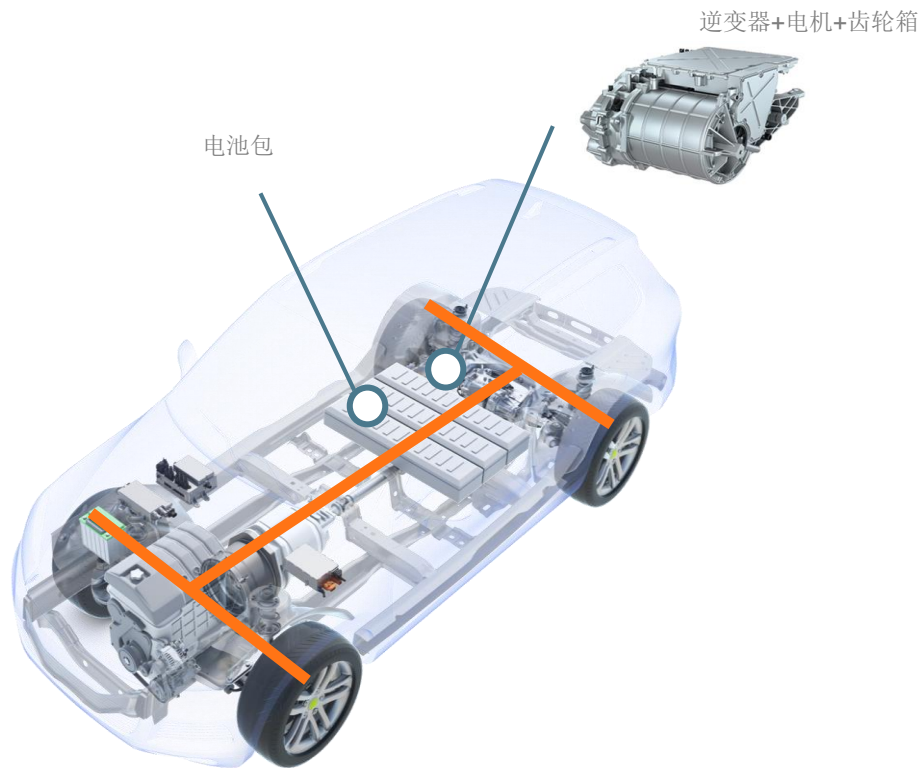

车用永磁同步电机控制系统介绍



自问自答

为什么选择Simulink 作为闭环仿真的环境?



建模方式的选择

FEM 软件	可以建立精准的有限元模型，仿真电机本体特性，无法与控制策略结合		
硬件电路设计软件	可以专门针对硬件电路进行仿真，无法对电机与控制策略进行联调		
Simulink	可以集成控制策略、逆变器模型、电机模型进行闭环仿真	Simulink + Stateflow 	强大的自定义设计

系统介绍

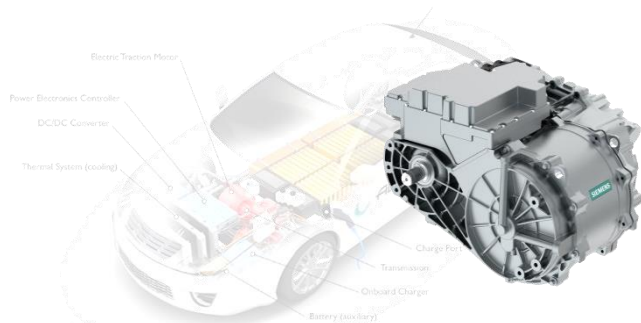

实体物理模型



通过Simulink可以将物理模型经过数学公式，转化为Simulink模型



$$v_{qs}^r = r_s i_{qs}^r + p L_q i_{qs}^r + \omega_r L_d i_{ds}^r + \omega_r \lambda_m$$
$$v_{ds}^r = r_s i_{ds}^r + p L_d i_{ds}^r - \omega_r L_q i_{qs}^r$$

物理数学公式

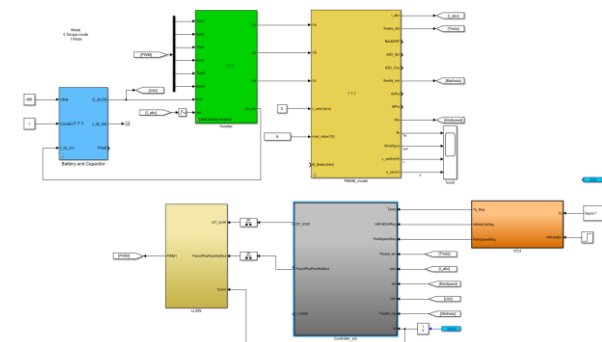

Simulink模型

控制系统搭建的要求

- 拟合真实性
- 可扩展性
- 广泛适用范围



结合实验数据的永磁同步电机模型建立

永磁同步电机控制系统的特点

永磁同步电机特点

- 扭矩脉动小
- 效率在中低转速区域最高
- 损耗低，相同功率下转子温度低
- 可提供大范围的恒定功率

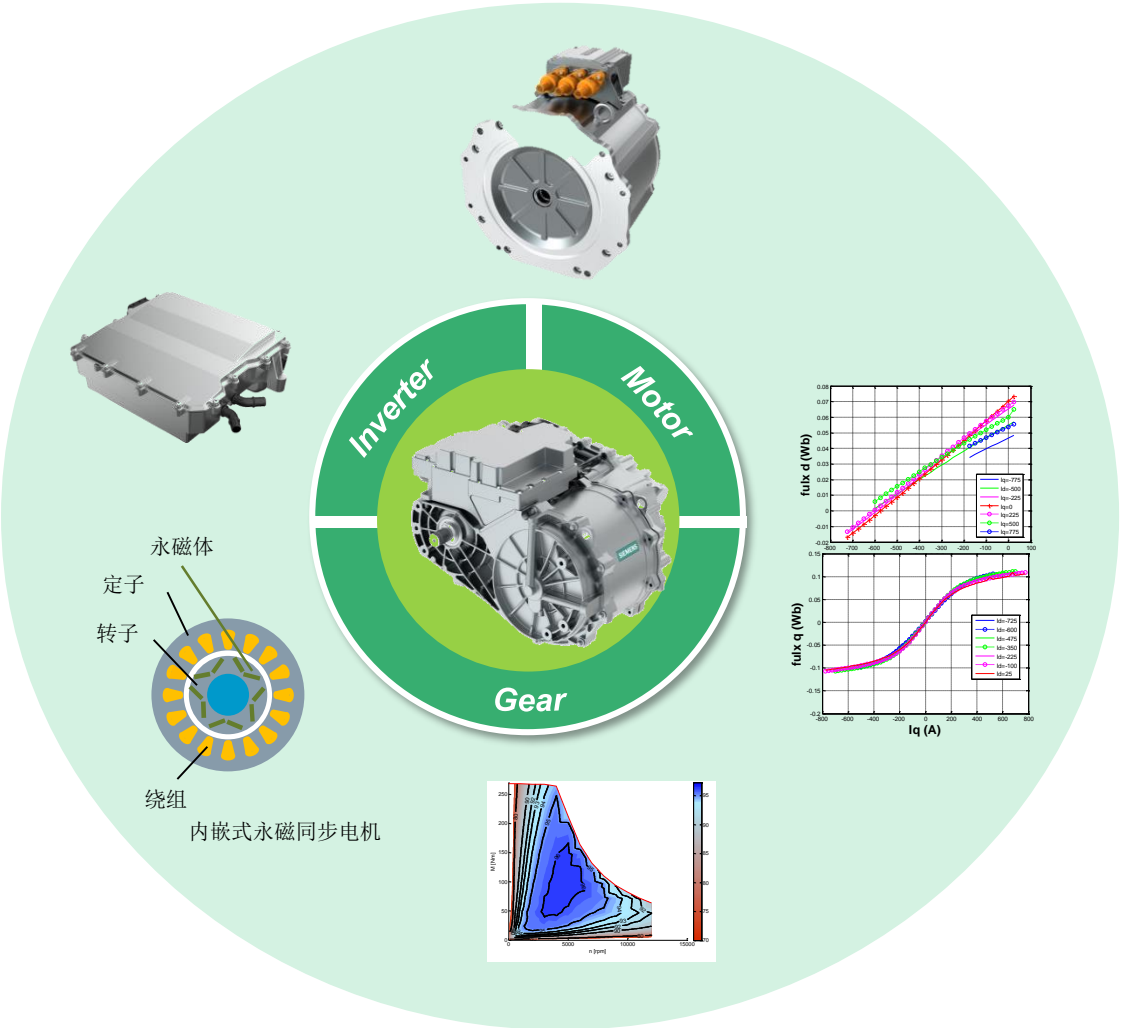

永磁同步电机常见的问题

磁饱和现象

温度对于永磁体的影响

铜损与铁损



谐波对于电机的影响

齿槽转矩

Resolver信号畸变

数学模型的建立

- 采用经典的电机数学模型
- 结合台架实际得到的性能参数



图1 电机等效电路



图2 电机台架参数

温度对于电机特性的影响

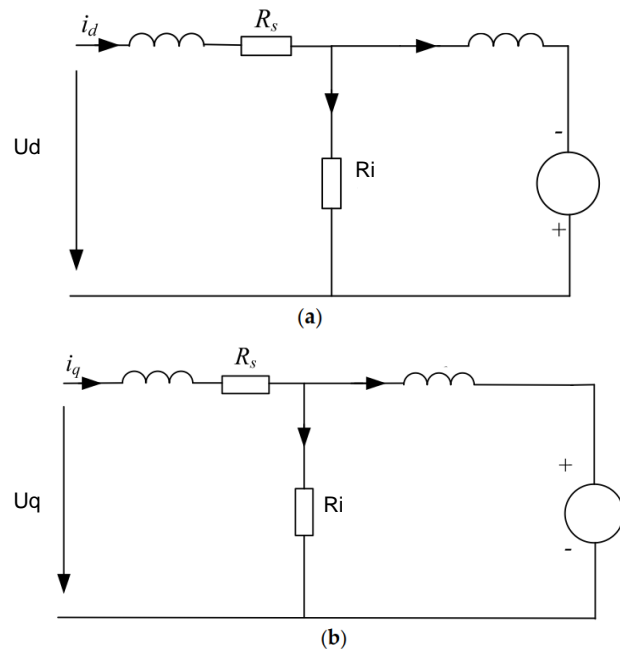
- 温度对于电机永磁体有非常大的影响
- 拟合的数据和实际数据保持较高的一致性

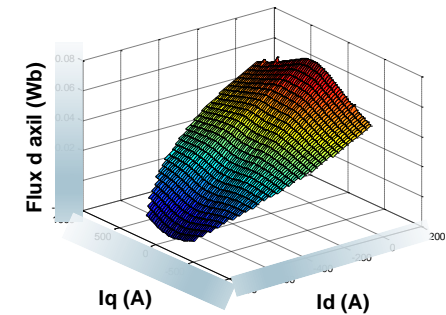
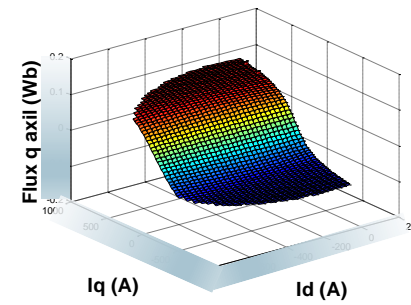
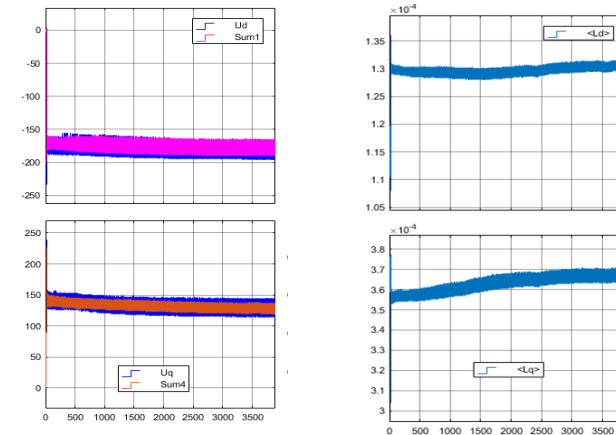

电压变化实际与测试一致

电感参数变化

图3 温度对于电机性能的影响



图1 温度对于永磁体磁感应强度的影响



图2 常见永磁体材料

考虑谐波对于电机的影响

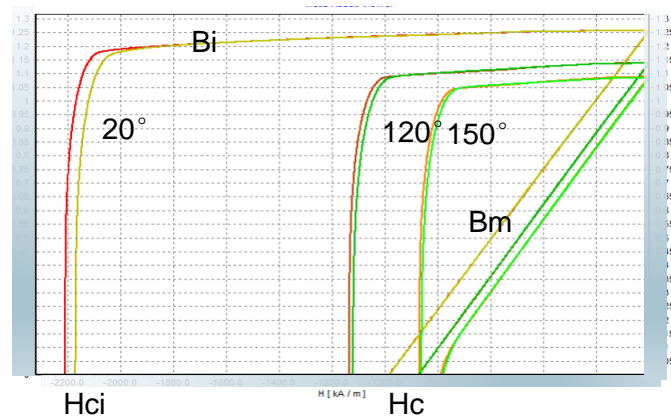
- 电机本体震动，会导致NVH相关的问题
- 经典的数据公式中不考虑谐波的影响
- 采用MATLAB Signal Analyzer 模块，可以轻松对数据进行频谱分析



图1 永磁同步电机的气隙磁场



图2 建模中将研究的相关谐波注入

Resolver 信号的产生

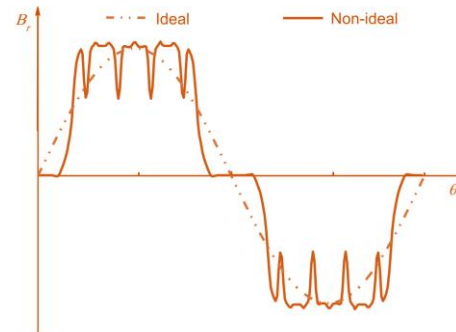
- Resolver是永磁同步电机常见的转速位置传感器
- Resolver 产生电压信号在实际中会存在一定的畸变和噪声

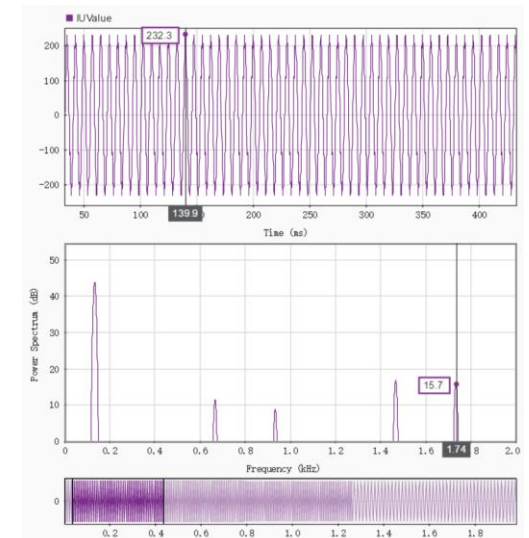

图4 Resolver 原理图



图1 Resolver 畸变信号

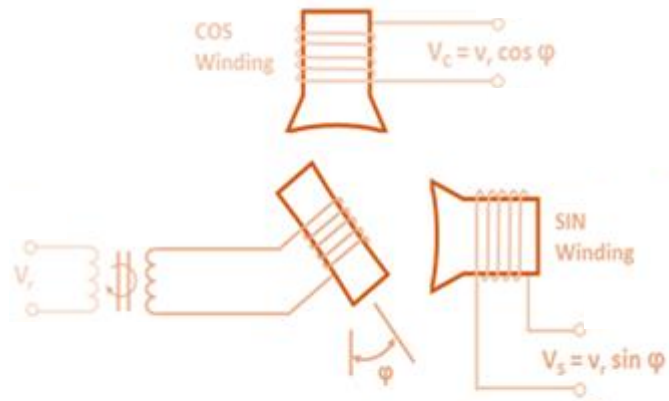

图2 Resolver 电压信号

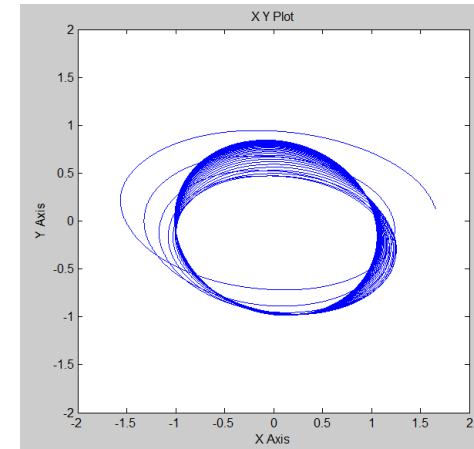

安装造成的非正交信号

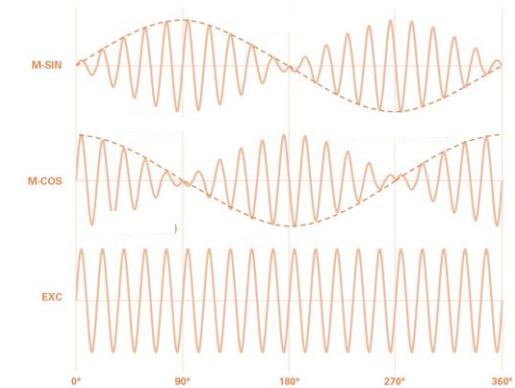
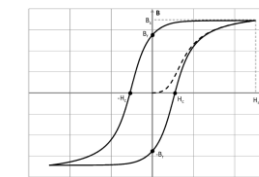

磁饱和现象

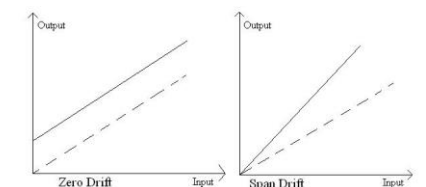

温度等造成的偏移

图3 Resolver 建模可以考虑实际存在的畸变

应用案例

➤ 齿槽转矩的仿真

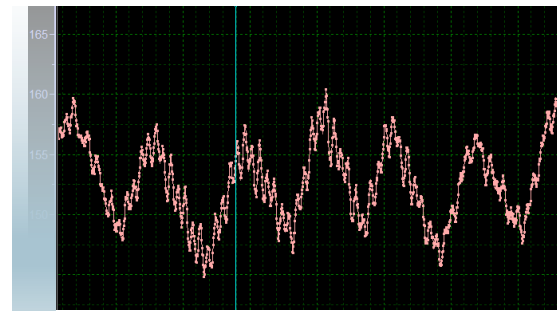

台架实测扭矩抖动

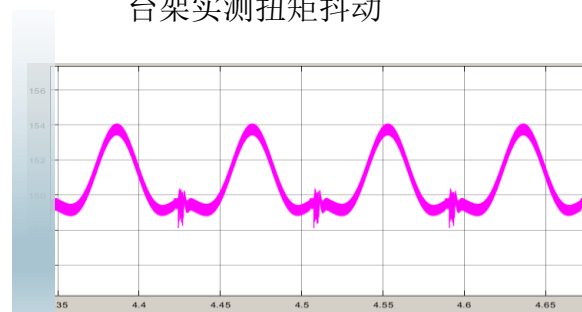

Simulink 数学公式仿真结果

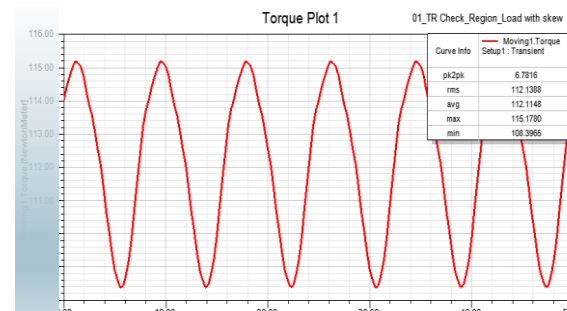

FEM仿真结果

三相逆变器

开关管路非线性

IGBT节温的影响

IGBT寿命



图1 三相逆变器原理图

热网络

热损耗

故障状态

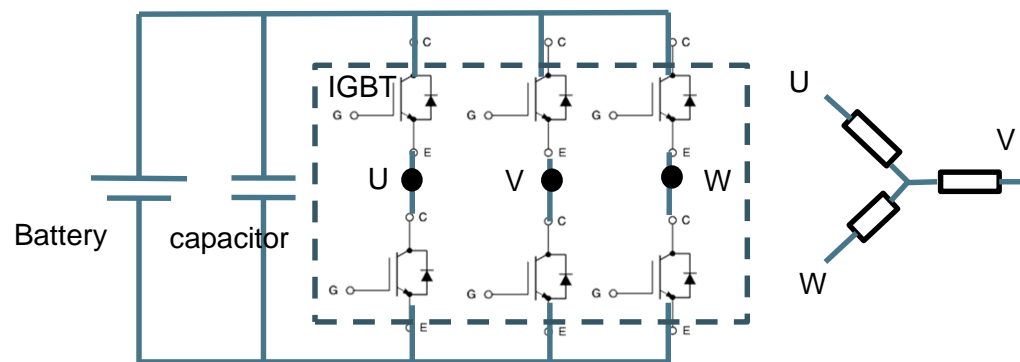

Control unit board

Power unit board

图2 三相逆变器实物图

死区时间与逆变器开关特性

- 真实的IGBT开关存在非线性
- 死区时间会导致电流流走根据电流方向不同，流走的器件不同



图1 三相逆变器原理图



图2 死区时间的电流走向

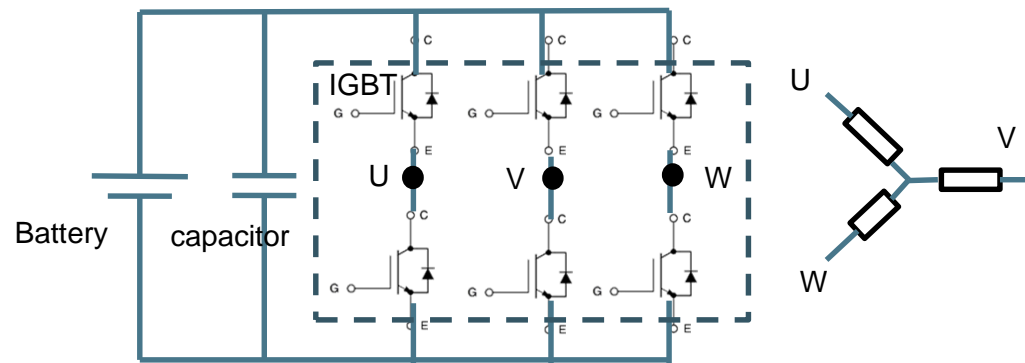

图3 考虑死区时间的原因

节温的仿真与评估

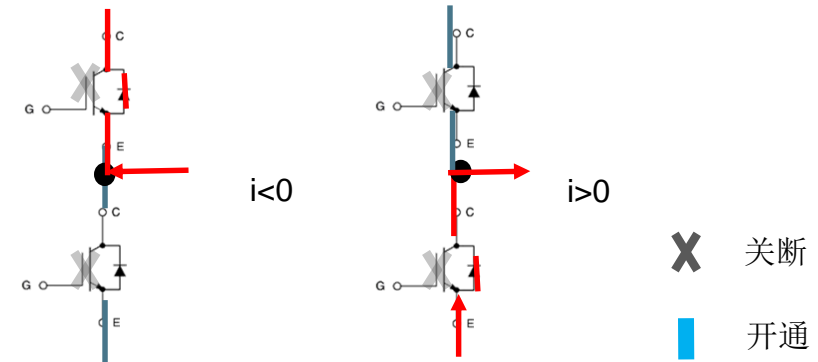
- 根据器件的特性和必要的热网络数据可以较为精确的估算出IGBT 器件的温度

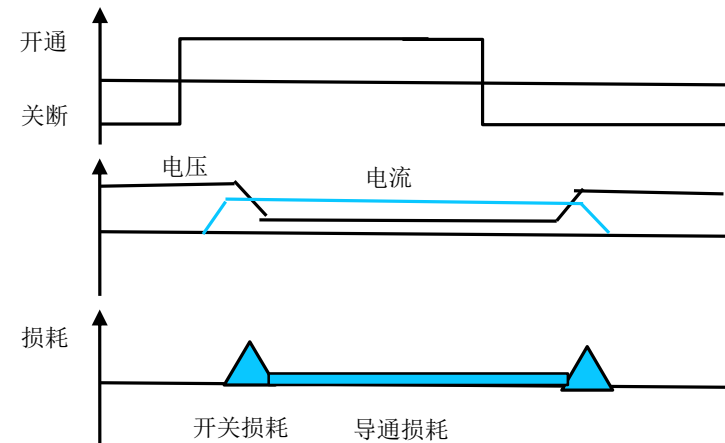

图3 热网络结构与等效



图1 仿真与真实节温对于系统的重要性

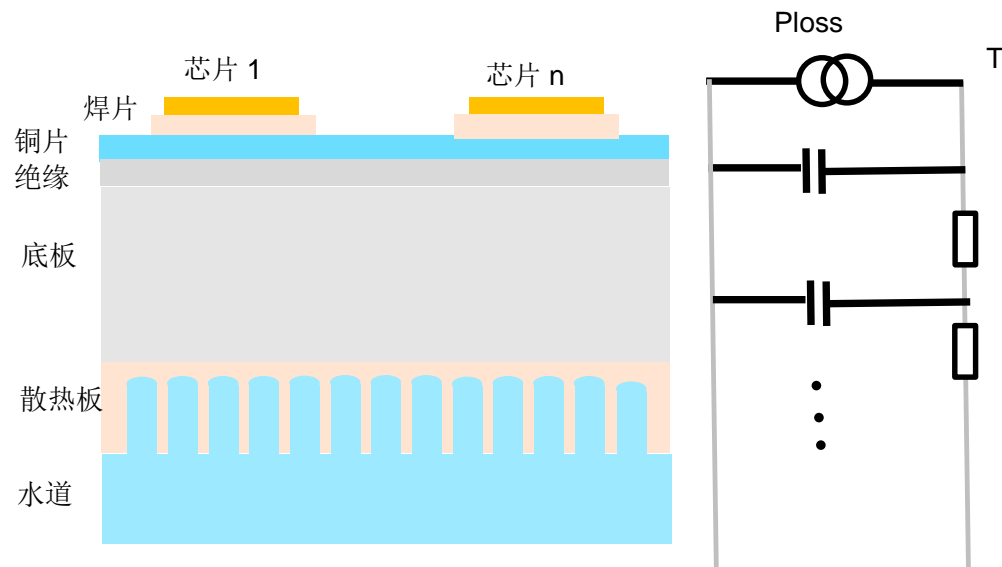

图2 仿真与传感器温度对比

主动短路与断路故障状态的仿真

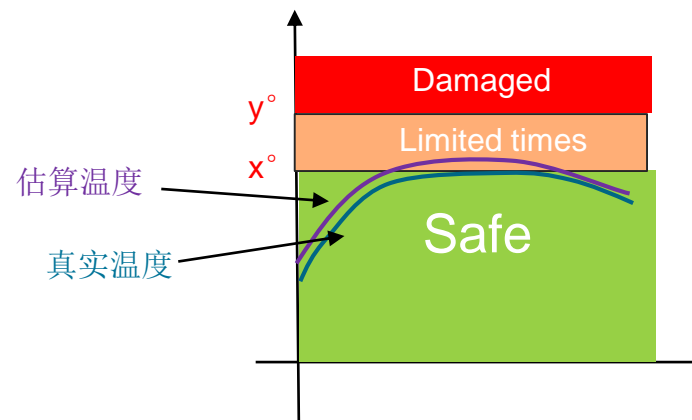
- 主动短路与断路是电机的常见故障状态，可以起到保护电机的作用

✘ 关断
■ 开通

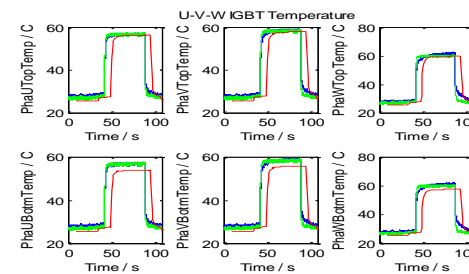

图1 主动短路与短路的结构特性

小结

- 考虑非线性特性的Inverter模型更接近真实

建模越接近真实，越复杂，越好吗？

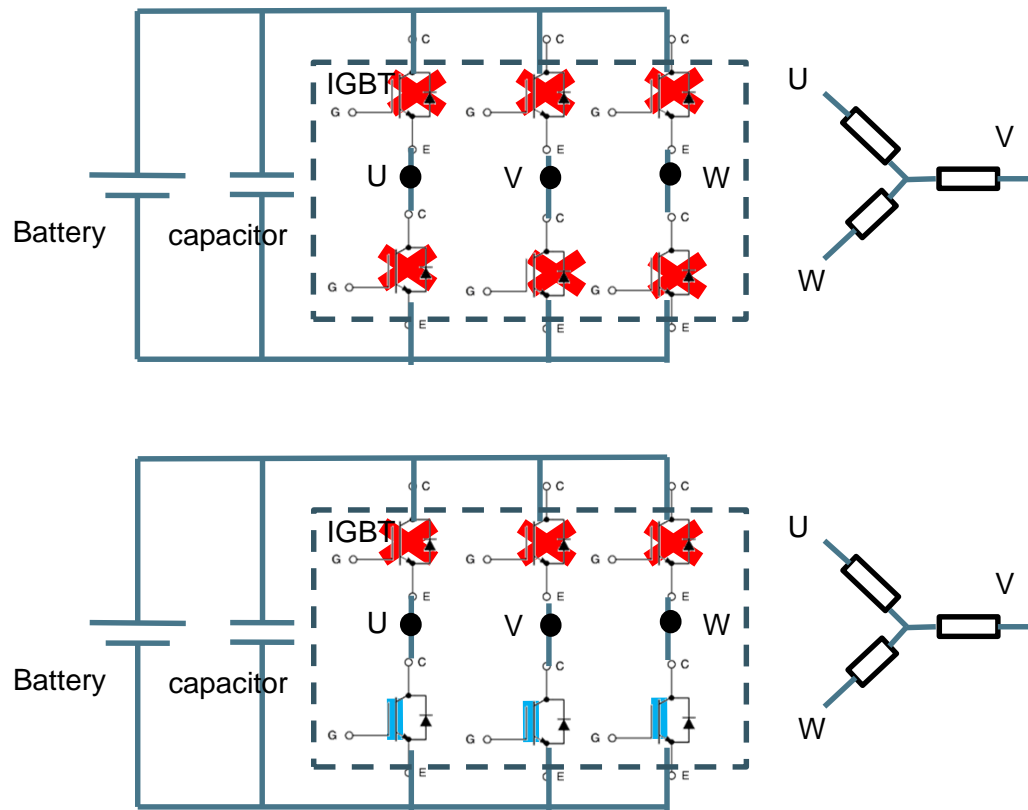

控制软件与被控对象模型的连接

- 控制软件模型与被控对象模型可以形成离线闭环模型
- 控制软件不同的步长可以借助 Simulink 子系统实现

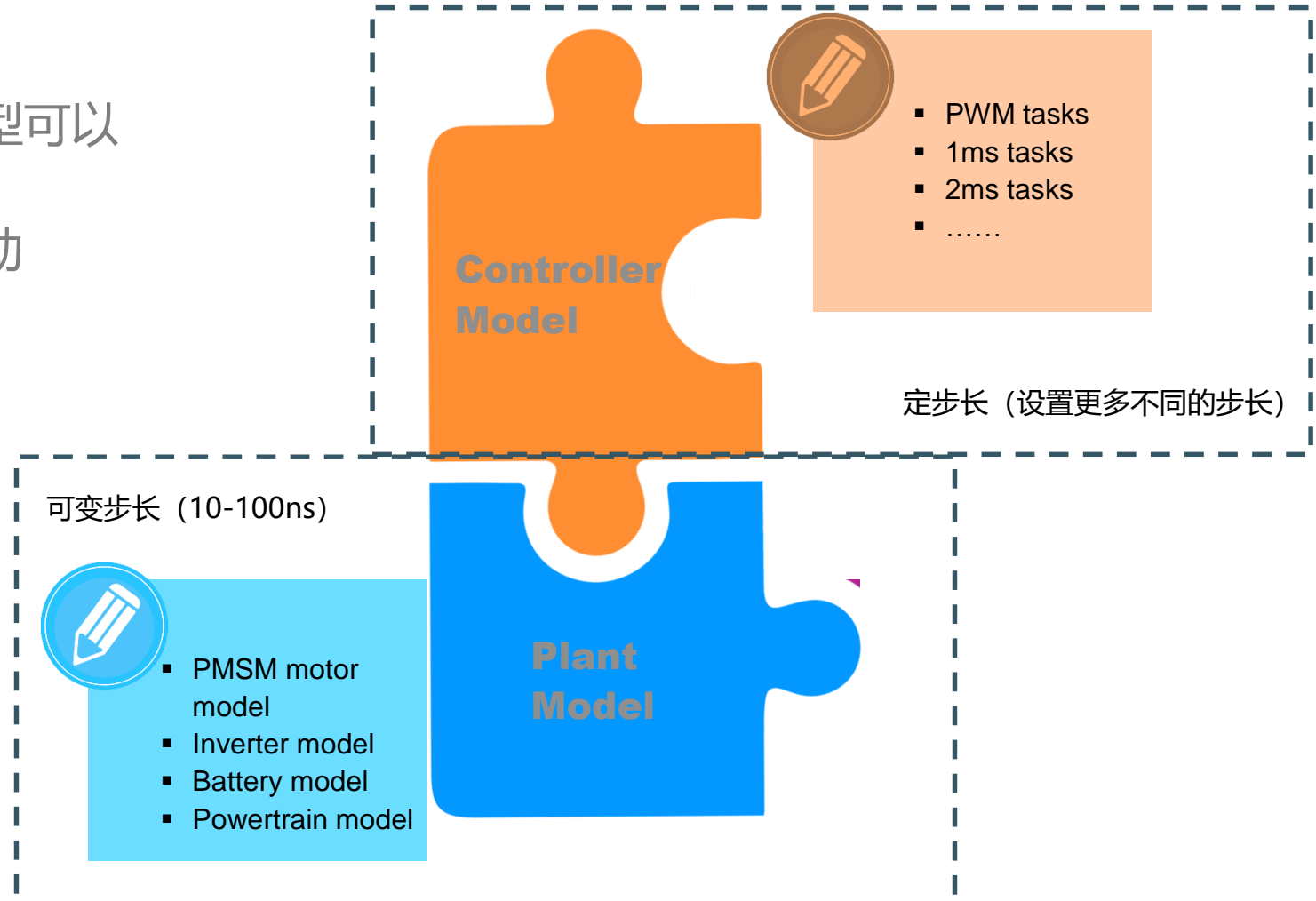
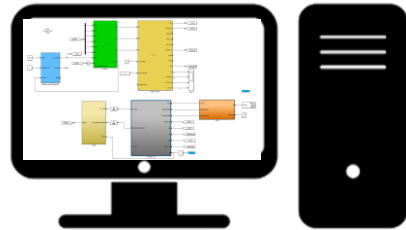

控制软件架构设计

- 控制软件模型需要与真实的软件架构保持基本一致
- 控制软件模型步长需要与真实软件保持一致



图1 常见任务的分配

自问自答

为什么要做离线仿真，有必要吗？



控制策略的早期验证的作用与效果

- 采取离线仿真验证，可以加速开发、在项目早期防止出现意外的疏漏直到单元测试或者软件测试才发现。降低人力成本

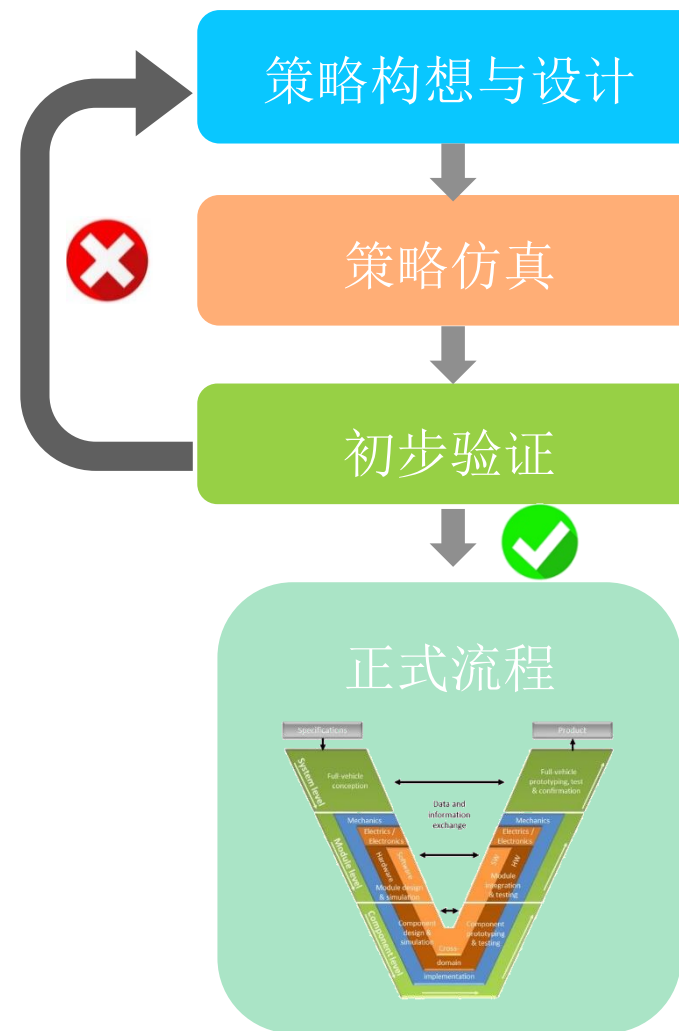

应用案例

➤ 起步情况下整车与电机抖动问题



图1 不考虑补偿情况下的整车起步



图2 考虑补偿情况下的整车起步

Simulink环境的控制策略早期验证

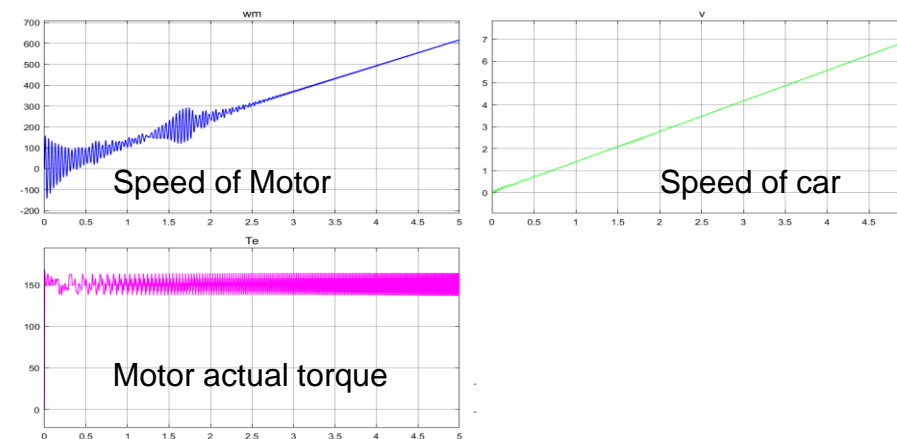
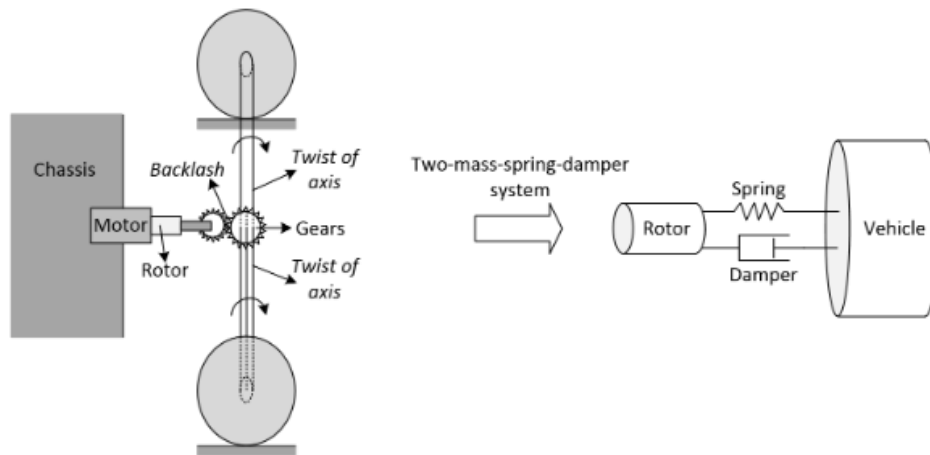
- 采用基于Simulink的建模可以扩展到多个开发场合

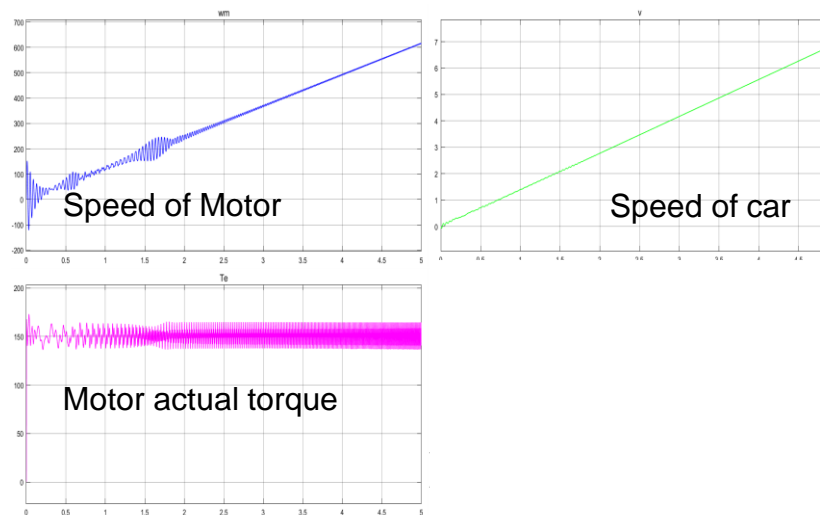

图1 离线仿真模型的扩展用途

小结

- 离线仿真助力软件开发

MATLAB 处理实验数据

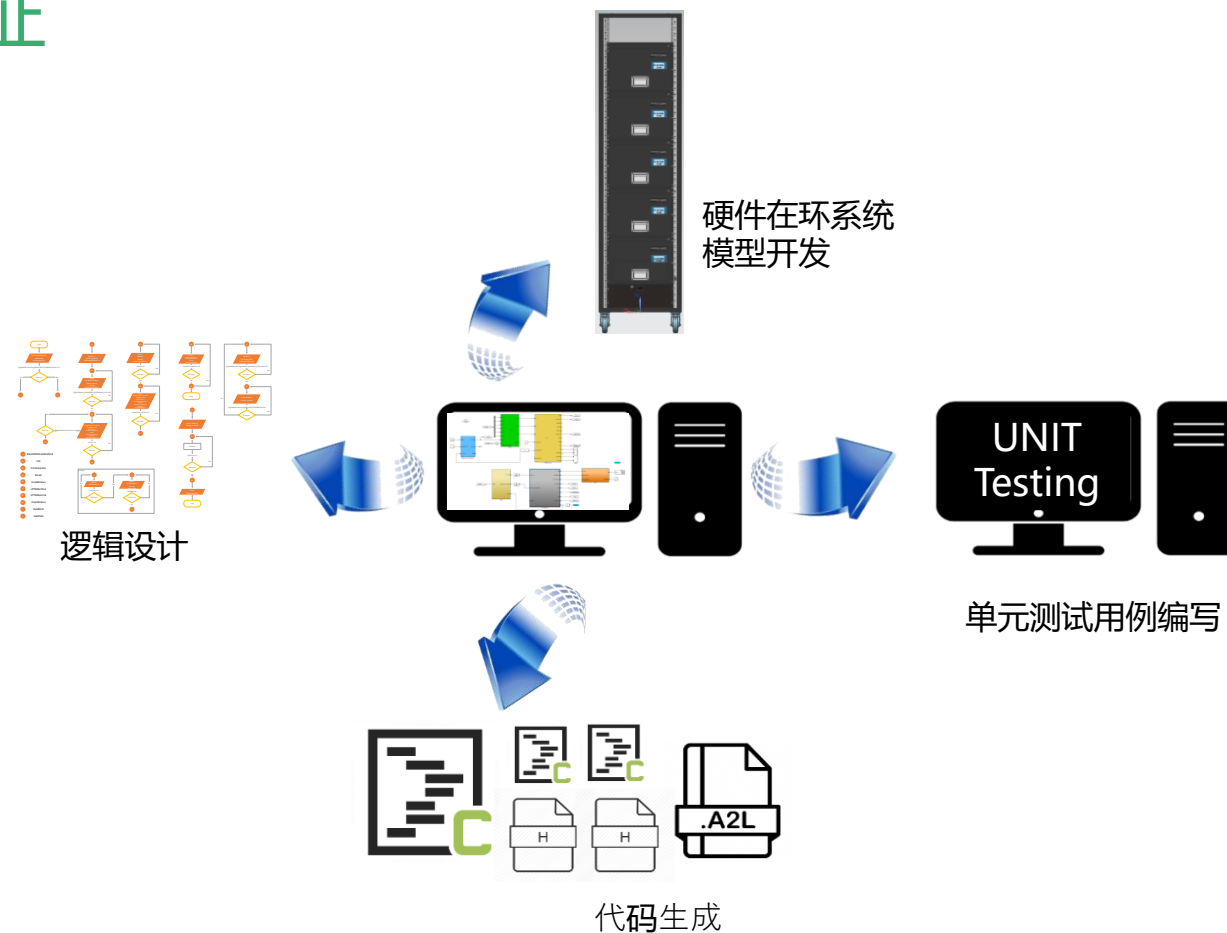
- 使用MATLAB脚本和工具箱可以对数据进行批量化处理，如电机电磁参数获取，控制策略最优数据得到

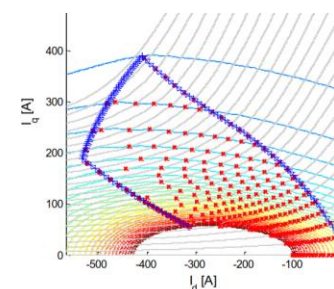

应用案例

➤ MATLAB Signal Analyzer

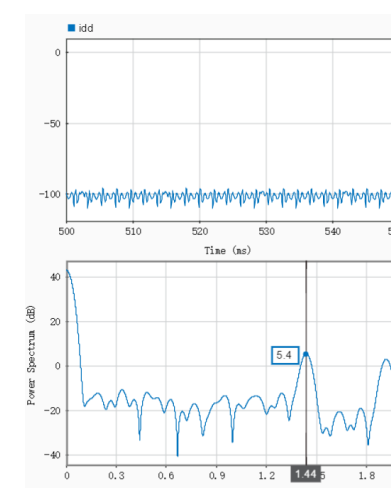
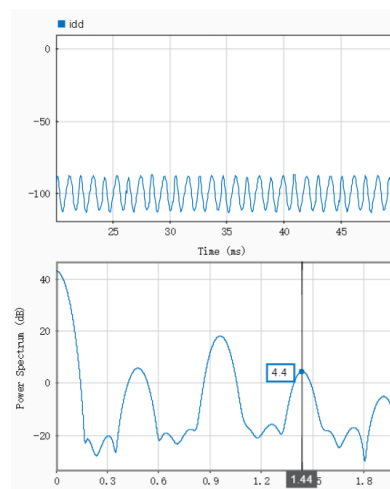
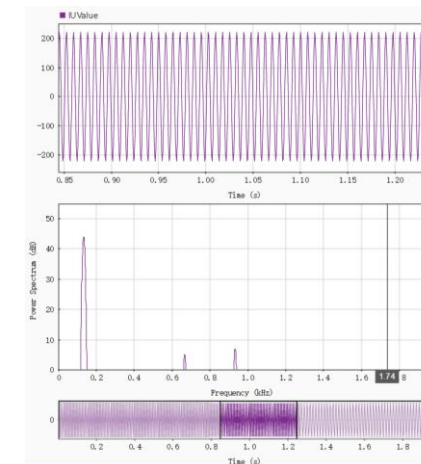
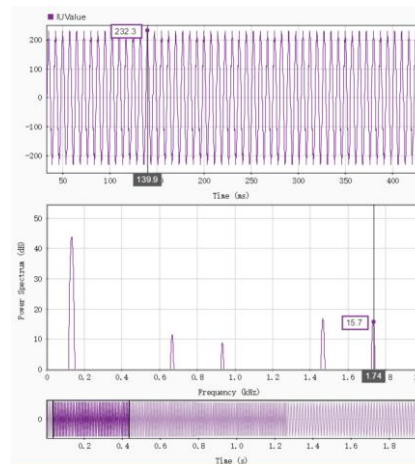

处理前

处理后

使用实验数据在Simulink中的二次验证

- 实验采集的数据导入到MATLAB环境中，可以作为输入对策略进行二次的验证

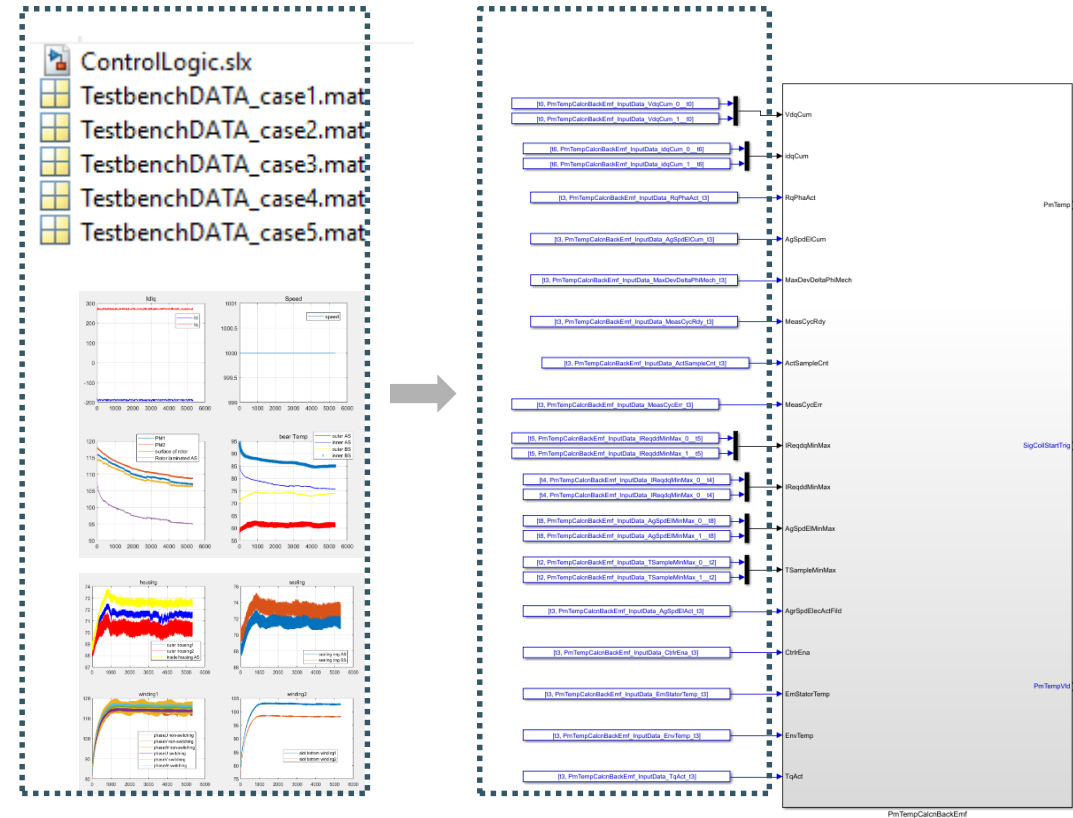

图1 离线仿真与台架数据结合

总结

- 离线控制仿真系统可以将真实的电机控制系统特性在Simulink环境中呈现
- 精准的模型需要精准的数学建模和详细的实验数据支撑
- 早期验证有助于加快开发进程

谢谢
The End